



UNIVERSAL DOWN DRAFT COOLER INSTALLATION KIT INSTALLATION INSTRUCTIONS

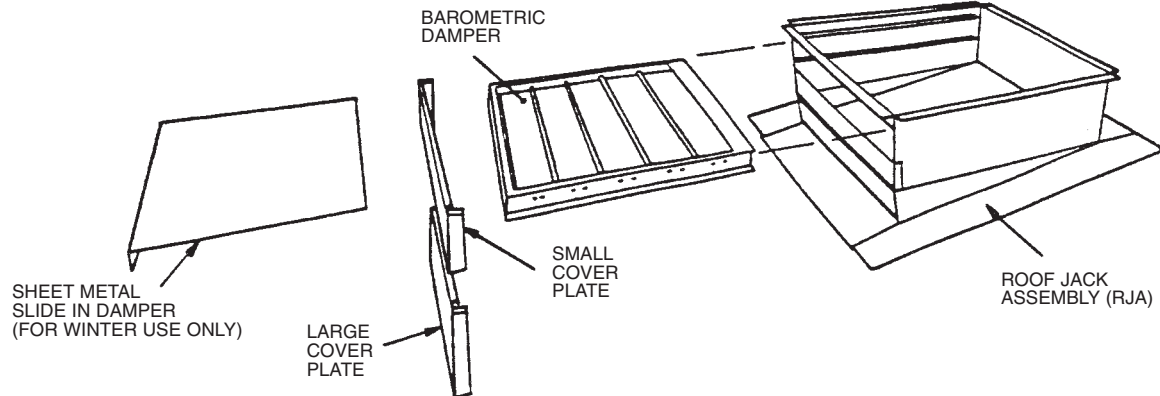

Figure 1. Cooler Installation Kit
(Note: Apron, Collar and Flex Duct Not Shown)

- Fits All Residential Down Draft Evaporative Coolers
- For New Evaporative Cooler Installations
- Patented Water Tight Rear Hinge Design
- For Flat To 4 x 12 Roof Pitches

IMPORTANT: Read All instructions prior to working with Cooler Installation Kit.

NOTE: Due to the wide variety of home constructions, these instructions should be used as a guideline for working with the Cooler Installation Kit. Where applicable, it may be necessary to vary from the suggested procedural steps in order to complete the installation.

Contents:

- 1, Roof Jack Assembly
 - 1, Barometric Damper
 - 1, Small Front Cover Plate
 - 1, Large Front Cover Plate
 - 1, Slide-In Damper
 - 12, Sheet Metal Self-Tapping Screws (used on Roof Jack Assembly)
 - 2, Apron
 - 2, Collar
 - 1, Flex Duct (18 inch diameter by 7 feet long)
- (Not Included:)
- Screws or nails to mount Roof Jack Assembly onto roof
 - Roofing Sealant
 - Caulking
 - Duct Tape

Installation Procedure:

1. Determine Roof Pitch:
2. This Roof Jack Assembly is designed to be used on roof pitches (slopes) from a flat roof up to a roof pitch of 4 x 12 (i.e. a 4 inch vertical rise by a 12 inch horizontal run). To determine the roof pitch, use a level

and measure the height up from the roof, at the point of 12 inches out from the roof (see Figure 2). For example, a measured height of 4 inches yields a roof pitch of 4 x 12.

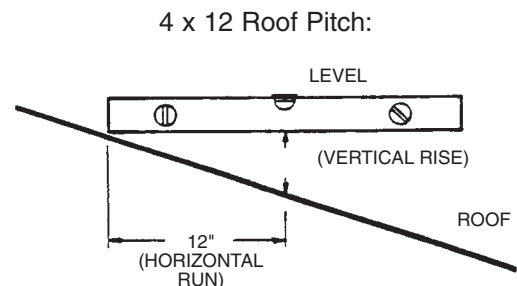

Figure 2. Determine Roof Pitch

2. Determine approximate roof location to mount Roof Jack Assembly:

Recommended locations are nearby an existing house air conditioning or heating duct, or nearby a central hallway within the house. Roof Jack Assembly location must also comply with local building codes.

3. Cut Hole Into Roof:

With the approximate location for the Roof Jack chosen from Step 2., finalize its placement by selecting a location that will allow for an 18 inch diameter hole to be cut into the roof, while not cutting through any roof joists. This may require access into the attic. Drill a pilot hole through the roof and use a saber (jig) saw (or equivalent tool) to cut the 18 inch diameter hole. The collar or apron can be used as an 18 inch template.

NOTE: The included flex duct length is 7 feet. If the distance from the roof hole to the final location of the flex duct (as described in Step 11.) exceeds 7 feet, additional flex duct will be needed. **CAUTION:** Over stretching of the flex duct can cause damage.

NOTE: If it is necessary to cut a roof joist in order to saw an 18" hole through the roof, it is recommended that the roof be resupported. This can be accomplished by mounting additional joists, both above and below the cut joist, that are perpendicular to the cut joist. These resupporting joists should span across from the two closest, non-cut joists.

4. Place and mount roof Jack Assembly Onto Roof:

Place Roof Jack bottom flange underneath roof shingles (slide from bottom shingle upwards) until the Roof Jack Assembly completely covers the 18 inch diameter hole. Secure Roof Jack to roof by nailing or screwing its bottom flange onto the roof.

5. Level Top of Roof Jack Assembly:

Top half of Roof Jack Assembly will pivot about its back hinge. With top half level, screw both top and bottom left side panels together. Re-level and screw both top and bottom right side panels together. Use four self-tapping screws for each panel side (see Figure 3).

IMPORTANT: Both the Roof jack Assembly and the Evaporative Cooler must be level to obtain maximum cooler performance.

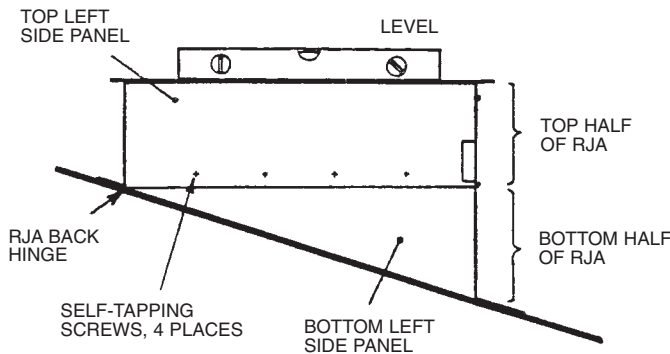

Figure 3. Leveling of Roof Jack Assembly (RJA)

6. Insert Barometric Damper:

Place Barometric Damper through front top hole of Roof Jack Assembly. Note the label on the barometric damper indicates the proper installation orientation (top front side) of the barometric damper.

7. Mount Front Cover Plates:

Place and mate small front cover plate interlocking lip with Roof Jack Assembly top front hole interlocking lip (see Figure 4).

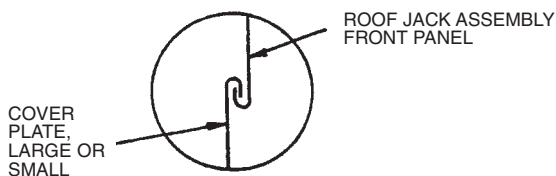

Figure 4. Mounting Cover Plate Onto RJA Front Panel

Use two self-tapping screws to fasten cover plate to Roof Jack Assembly. Repeat above procedure for large front cover plate and Roof Jack Assembly bottom hole.

NOTE: For small roof pitches, the installation of the front cover plates may differ from that specified above. The two cover plates need to be interchanged (small on bottom and large on top), or only one is needed.

8. Seal Roof Jack Assembly:

a. If needed, apply caulking in between left hand side panels of Roof Jack Assembly. Repeat (if needed) for right hand side panels.

b. Liberally apply roofing sealant to all bottom interfaces of Roof Jack Assembly and roof shingles. Roofing sealant may also need to be applied to cover up roofing nails or screws used to mount Roof Jack Assembly bottom flange onto roof. Roofing sealant will provide a weatherproof, water tight seal between the Roof Jack Assembly and the roof shingles.

c. Prior to placing Evaporative Cooler onto Roof Jack Assembly top, apply caulking to Roof Jack Assembly top flange.

IMPORTANT: ATTIC ACCESS WILL TYPICALLY BE REQUIRED FOR THE COMPLETION OF THIS INSTALLATION.

9. Connect Apron To Collar:

Bend every other collar tab outward by 90° (See Figure 5). Place apron onto bent collar tabs. Bend remaining straight tabs outward onto apron. This will interlock collar onto apron. Place duct tape on outside interface of collar, tabs, and apron.

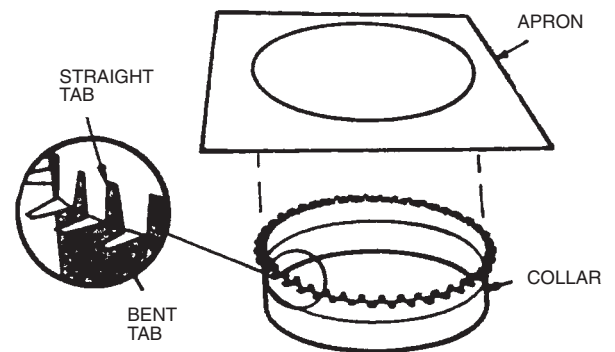

Figure 5. Connecting Apron To Collar

10. Secure Apron to Roof:

Mount apron/collar assembly to the underside (attic side) of the 18 inch diameter Roof Jack Assembly hole.

11. Choose Evaporative Cooler Air Inlet Method:

The method to deliver the evaporative cooler air into the house must be chosen. The two methods available are:

- a. To connect the flex duct to the existing house central air conditioning and heating main ducting (a rectangularly shaped main duct is required), or
- b. To deliver the air into a central, or main, hallway.

11.a). Connection (Air Delivery) To Main Ducting:

11.a).1). Cut Hole Into Existing Duct:

Choose location for 18 inch diameter hole to be cut into existing ducting. Use collar as a template. Drill pilot hole(s) into duct. Use saber (jig) saw (or equivalent tool) to cut hole into ducting.

11.a).2). Connect Collar To Main Ducting:

Bend every other collar tab outward by 90°. Place collar into ducting hole. Reach through hole and bend remaining straight tabs outward onto ducting. This will interlock the collar onto the ducting. Place duct tape on outside interface of collar, tabs, and duct.

11.a).3). Connect Flex Duct To Roof Collar:

Slide flex duct over collar by 2 to 4 inches. Use duct tape to fasten flex duct onto collar. Hint: For a more secure flex duct to collar connection, use self-tapping screws and washers to support the flex duct wire up against collar.

11.a).4). Position Flex Duct From Roof Collar To House Ducting Collar:

Position flex duct from roof collar to ducting collar so that no sharp bends remain within flex duct. It is best to cut extra flex duct to avoid excessive or sloppy bends. Keeping flex duct as straight as possible typically lends to the best flex duct installation.

11.a).5). Connect Flex Duct To House Ducting Collar:

Complete this step by repeating Step 11.a).3)., above.

11.b). Air Delivery To Central Hallway:

11.b).1). Cut Hole Into Hallway Ceiling:

Choose location for 18 inch diameter hole to be cut into hallway ceiling. Be careful to avoid all ceiling joists. Use collar as template. Drill pilot hole(s) into ceiling. Use saber (jig) saw (or equivalent tool) to cut hole into ceiling.

11.b).2). Connect Apron To Collar:

Complete this step by repeating Step 9., above.

11.b).3). Mount Apron To Ceiling Joist Inside Attic:

Prior to securing apron to ceiling joist, it may be necessary to create a "joist box". Cut and mount additional wood joists perpendicular to the two closest ceiling joists to create a square "joist box". Add caulking to joints to make this "joist box" relatively air tight. Finally, secure apron onto ceiling "joist box".

11.b).4). Connect Flex Duct To Roof Collar:

Slide flex duct over collar by 2 to 4 inches. Use duct tape to fasten flex duct onto collar. Hint: For a more secure flex duct to collar connection, use self-tapping screws and washers to support the flex duct wire up against collar.

11.b).5). Position Flex Duct From Roof Collar To Ceiling Collar:

Position flex duct from roof collar to ceiling collar so that no sharp bends remain within flex duct. It is best to cut extra flex duct to avoid excessive or sloppy bends. Keeping flex duct as straight as possible typically lends to the best flex duct installation.

11.b).6). Connect Flex Duct To Ceiling Collar:

Complete this step by repeating Step 11.b).4)., above.

NOTE:

For winterizing evaporative cooler, remove top front cover plate, place slide-in damper into Roof Jack Assembly, and remount top front cover plate.

IMPORTANT:

The Roof Jack Assembly is not designed to fully support the Evaporative Cooler during normal operating conditions. An additional cooler support system, such as a Cooler Leg Kit, is required.
